

2-WIRE PROGRAMMABLE TRANSMITTER



- RTD, TC, Ohm, or mV input
- Extremely high measurement accuracy
- 1.5 kVAC galvanic isolation
- Programmable sensor error value
- For DIN form B sensor head mounting



Application:

- Linearised temperature measurement with Pt100...Pt1000, Ni100...Ni1000, or TC sensor.
- Conversion of linear resistance variation to a standard analogue current signal, for instance from valves or Ohmic level sensors.
- Amplification of a bipolar mV signal to a standard 4...20 mA current signal.

Technical characteristics:

- Within a few seconds the user can program PR5331B, C & D to measure temperatures within all ranges defined by the norms.
- The RTD and resistance inputs have cable compensation for 2-, 3- and 4-wire connection.
- Continuous check of vital stored data for safety reasons.

Mounting / installation:

- For DIN form B sensor head mounting.
- **NB:** As Ex barrier we recommend 5104B, 5114B, or 5116B.

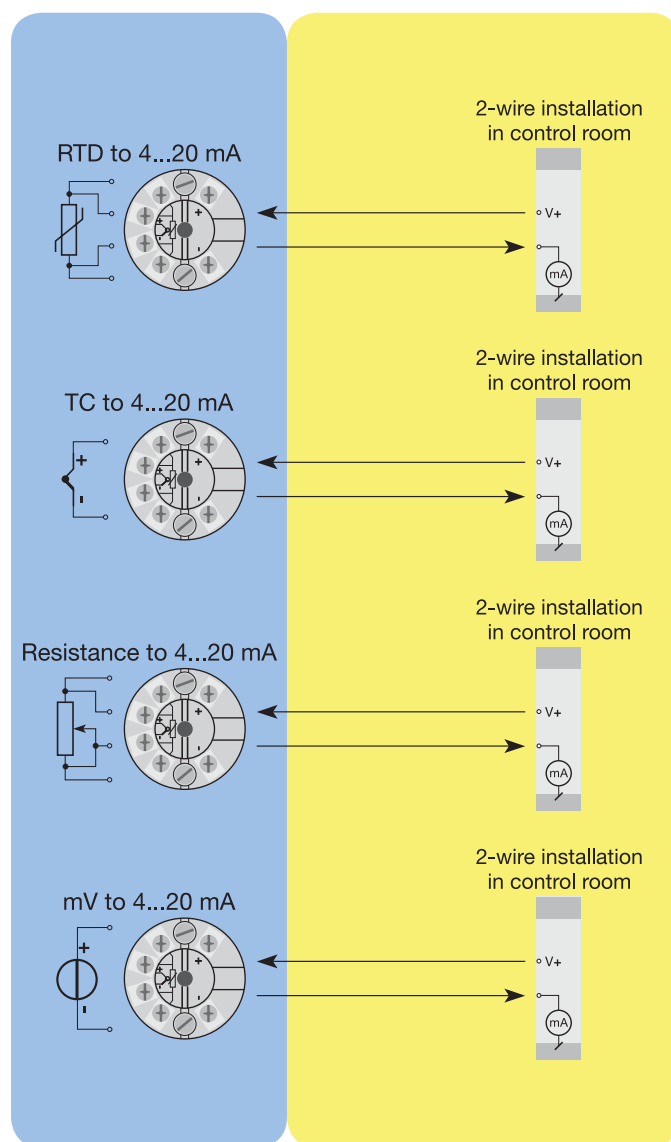

Order: 5331

Type	Version	Ambient-temperature	Galvanic isolation
5331	ATEX : B	-40°C...+85°C : 3	1500 VAC : B
	FM and ATEX : C		
	CSA, FM and ATEX : D		

Connections:

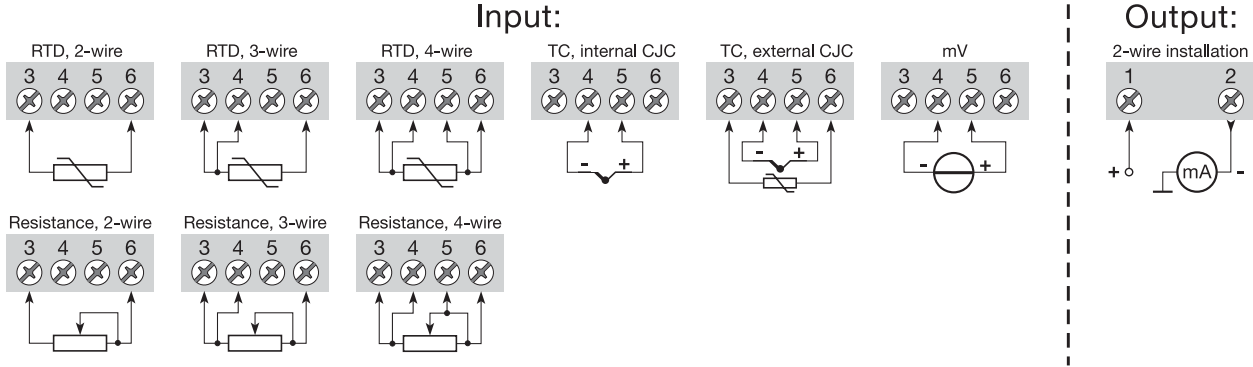

Electrical specifications:

Specifications range:

-40°C to +85°C

Common specifications:

- Supply voltage, DC 7.2...28 V
- Voltage drop 7.2 VDC
- Isolation voltage, test / operation 1.5 kVAC / 50 VAC
- Communications interface Loop Link
- Signal / noise ratio Min. 60 dB
- Signal dynamics, input 20 bit
- Signal dynamics, output 16 bit
- Accuracy, the greater of general and basic values:

General values		
Input type	Absolute accuracy	Temperature coefficient
All	≤ ±0.05% of span	≤ ±0.01% of span / °C

Basic values		
Input type	Basic accuracy	Temperature coefficient
RTD	≤ ±0.2°C	≤ ±0.01°C/°C
Lin.R	≤ ±0.1 Ω	≤ ±10 mΩ/°C
Volt	≤ ±10 μV	≤ ±1 μV/°C
TC type: E, J, K, L, N, T, U	≤ ±1°C	≤ ±0.05°C/°C
TC type: B, R, S, W3, W5, LR	≤ ±2°C	≤ ±0.2°C/°C

EMC immunity influence	< ±0.5% of span
Extended EMC immunity: NAMUR NE 21, A criterion, burst	< ±1% of span

- Vibration IEC 60068-2-6 Test FC
- Lloyd's specification no. 1 4 g / 2...100 Hz
- Humidity < 95% RH (non-cond.)
- Dimensions Ø 44 x 20.2 mm
- Tightness (enclosure / terminal) IP68 / IP00

Electrical specifications, input:

Max. offset 50% of selec. max. value

RTD and linear resistance input:

RTD type	Min. value	Max. value	Min. span
Pt100	-200°C	+850°C	25°C
Ni100	-60°C	+250°C	25°C
Lin.R	0 Ω	5000 Ω	30 Ω

Cable resistance per wire (max.) 5 Ω

Sensor current Nom. 0.2 mA

TC input:

Type	Min. temperature	Max. temperature	Min. span	Norm
B	+400°C	+1820°C	200°C	IEC584
E	-100°C	+1000°C	50°C	IEC584
J	-100°C	+1200°C	50°C	IEC584
K	-180°C	+1372°C	50°C	IEC584
L	-100°C	+900°C	50°C	DIN 43710
N	-180°C	+1300°C	100°C	IEC584
R	-50°C	+1760°C	200°C	IEC584
S	-50°C	+1760°C	200°C	IEC584
T	-200°C	+400°C	50°C	IEC584
U	-200°C	+600°C	75°C	DIN 43710
W3	0°C	+2300°C	200°C	ASTM E988-90
W5	0°C	+2300°C	200°C	ASTM E988-90
LR	-200°C	+800°C	50°C	GOST 3044-84

Cold junction compensation < ±1.0°C

Voltage input:

Measurement range -12...800 mV

Min. span 5 mV

Current output:

Signal range 4...20 mA

Min. signal range 16 mA

Updating time 440 ms

Load resistance ≤ (Vsupply - 7.2) / 0.023 [Ω]

Sensor error detection:

Programmable 3.5...23 mA

Ex / I.S. data:

Ui : 28 VDC

Ij : 120 mA

Pi : 0.84 W

Lj : 10 μH

Ci : 1.0 nF

EEx / I.S. approval:

DEMKO 99ATEX126962 II 1 G

EEx ia IIC T1...T6

Max. amb. temperature for T1...T4 ... 85°C

Max. amb. temperature for T5 and T6 ... 60°C

Applicable in zone 0, 1 or 2

FM, applicable in IS, Cl. I, Div. 1, Gr. A, B, C, D

Entity, FM Installation Drawing No. ... 5300Q502

CSA, applicable in IS, Cl. I, Div. 1, Gr. A, B, C, D

Ex ia IIC

IS, Cl. I, Zone 0, AEx ia IIC

Installation Drawing No. 533XQC03

Marine approval:

Det Norske Veritas, Ships & Offshore. Stand. for Certification 2.4

Observed authority requirements: Standard:

EMC 2004/108/EC

Emission and immunity EN 61326

ATEX 94/9/EC EN 50014 and EN 50020

FM, ASCN 3600, 3611, 3610

CSA, CAN / CSA C22.2 No. 157, E60079-11, UL 913

Of span = Of the presently selected range