

# PROGRAMMABLE LCD/LED INDICATOR



- 4-digit LCD/LED indicator
- PC-programmable
- Galvanically isolated 3.75 kVAC
- Scaling via front function keys
- Current / voltage or temperature input
- IP65 tightness from front



#### General:

The indicator 5515 is used for digital readout of current / voltage or temperature signals.

The indicator is configured from factory acc. to specifications or the user can do the configuration himself by means of the configuration kit Loop Link and a PC.

The indicator with a unipolar current and voltage input can be programmed up to 100 mA and 250 VDC. This indicator contains a transmitter supply.

If an indicator with a temperature input is chosen, signals from standard Pt100 and thermocouples and mV signals can be measured.

With the front-operated keys it is possible to scale the display readout and the placing of decimal points if this function has been chosen actively in the software.

The indicator is galvanically separated which means that both grounded and floating signals can be measured.

#### Input types for 5515 A1/B1:

**Thermocouple input (TC)** for standard thermocouples in the temperature ranges acc. to the standards IEC 584, DIN 43710 or ASTM E988-90. The CJC compensation is implemented with a Pt100 sensor in the terminal (option - type 5914), external Pt100 sensor/Ni100 in 2-wire connection or fixed CJC (thermostat box).

**Unipolar mV input** for DC voltage signals.

**RTD input** for Pt100/Ni100 in temperature range acc. to IEC 751 or DIN 43760 standards. Via the PReset program the cable resistance can be measured in a 2-wire connection.

Automatic cable compensation by 3- or 4-wire sensor connection.

**Resistance input** for ohmic resistance measurement, max. range 5000  $\Omega$ .

Automatic cable compensation by 3- or 4-wire connection.

#### Input types for 5515 A2/B2:

**Current input** for unipolar DC current signal up to 100 mA. The input is protected by a PTC resistor.

**Voltage input** for unipolar DC voltage signal up to 250 VDC.

**Auxiliary supply** 19.5 VDC / 20 mA for supply of 2-wire transmitter.

**Linearisation** is possible acc. to customer specifications.

#### Display:

4-digit backlit LCD or LED display with respectively 16 mm (LCD) and 14.2 mm (LED) digit height. Max. display readout  $\pm 9999$  with selectable decimal point. Can be scaled via either the configuration kit Loop Link or via the front keyboard. The readout can be reversed by setting min. readout higher than max. readout. The display shows »In.HI« if the input is  $\sim 3.5\%$  above the measurement range and »In.Lo« if the input is more than  $\sim 7\%$  below the measurement range. For indicators with temperature input, sensor error is indicated by »SENS« in the display. During the communication the display switches off, as communication is possible without connection of supply to the unit.

#### Special version - 5515A--PEAK:

5515A--PEAK is a special version of the standard 5515 indicator. The peak function continuously stores the min. and max. display readout in the memory. The min. and max. values can be displayed by pressing a single key for each value. The peak function is available only in the 5515 with LED display.

#### Installation:

Loop Link contains PReset software, adapter box, cable, etc. The adapter box is galvanically isolated which protects the PC.

The communication is a two-way communication, which means that the previous set-up and series / tag number can be retrieved from the indicator.

## Electrical specifications:

### Specifications range:

-20°C to +60°C

### Common specifications:

Supply voltage:

5515--A .....	103.5...126.5 VAC, 50...60Hz
5515--B .....	207...253 VAC 50...60Hz
5515--D .....	19.2...28.8 VDC / 21.6...26.4 VAC, 50...60Hz

Internal consumption

5515A LED .....	< 3 W
5515B LCD .....	< 1.5 W
Isolation voltage test / operation .....	3.75 kVAC / 250 VAC
Communication .....	Loop Link
Response time (programmable) .....	1...60 s
Signal dynamics, input .....	20 bit
Calibration temperature .....	20...28°C
Temperature coefficient .....	< 0.01% of span/°C
Linearity error .....	< ±0.1% of span
Effect of supply voltage change .....	≤ 0.002% of span / % V
Auxiliary voltage 5515 A2/B2:	
2-wire supply (pin 44...42) .....	≥ 19.5 VDC / 20 mA
EMC immunity influence .....	< ±0.5% of span
Max. wire size .....	1 x 2.5 mm <sup>2</sup> stranded wire
Screw terminal torque .....	0.5 Nm
Relative air humidity .....	< 95% RH (non-cond.)
Dimensions (HxWxD) .....	48 x 96 x 120 mm
Panel cut-out .....	44.5 x 91.5 mm
Tightness (mounted in a panel) .....	IP65
Weight .....	210 g

### Electrical specifications - INPUT type 5515-1:

#### TC input:

Type	Min. temp.	Max. temp.	Min. span (5 mV)	Standard
B	+400°C	+1820°C	200°C	IEC584
E	-100°C	+1000°C	50°C	IEC584
J	-100°C	+1200°C	50°C	IEC584
K	-180°C	+1372°C	50°C	IEC584
L	-100°C	+900°C	50°C	DIN43710
N	-180°C	+1300°C	100°C	IEC584
R	-50°C	+1760°C	200°C	IEC584
S	-50°C	+1760°C	200°C	IEC584
T	-200°C	+400°C	50°C	IEC584
U	-200°C	+600°C	75°C	DIN43710
W3	0°C	+2300°C	200°C	ASTM E988-90
W5	0°C	+2300°C	200°C	ASTM E988-90

Max. offset .....	50% of selec. max. value
Sensor current .....	Nom. 100 nA
Basic accuracy:	
Type E, J, K, L, N, T, U .....	< ±1°C
Type B, R, S, W3, W5 .....	< ±2°C
Cold junction compensation .....	< ±1°C
Temperature coefficient	
Type E, J, K, L, N, T, U:	
span < 500°C .....	< ±0.05°C / °C <sub>amb.</sub>
span > 500°C .....	< ±0.01% of span/°C <sub>amb.</sub>
Type B, R, S, W3, W5 .....	< ±0.2°C / °C <sub>amb.</sub>
Sensor error detection .....	Indicated in display

#### mV input:

Measurement range .....	0...100 mV
Min. measurement range .....	5 mV
Max. offset .....	50% of selec. max. value
Input resistance .....	Nom. 10 MΩ

### RTD / lin. R input:

Type	Min. value	Max. value	Min. span	Standard
Pt100	-200°C	+850°C	25°C	IEC 60751
Ni100	-60°C	+250°C	25°C	DIN 43760
Lin. R	0 Ω	5000 Ω	30 Ω	-----

Max. offset .....	50% of selec. max. value
Cable resistance per wire (max.) .....	10 Ω
Sensor current .....	Nom. 0.2 mA
Basic accuracy .....	< ±0.2°C
Temperature coefficient:	
Span < 100°C .....	< ±0.01°C / °C <sub>amb.</sub>
Span > 100°C .....	< ±0.01% of span/°C <sub>amb.</sub>
Effect of sensor cable resistance (3- / 4-wire) .....	< 0.002 Ω/Ω
Sensor error detection (only RTD) .....	Indicated in display

### Electrical specifications - INPUT type 5515-2:

#### Voltage input:

Measurement range .....	0...250 VDC
Min. measurement range (span) .....	50 mVDC
Max. offset .....	50% of selec. max. value
Input resistance ≤ 2.5 VDC .....	Nom. 10 MΩ
> 2.5 VDC .....	Nom. 5 MΩ

#### Current input:

Measurement range .....	0...100 mA
Min. measurement range (span) .....	4 mA
Max. offset .....	50% of selec. max. value
Input resistance:	
Powered unit .....	10 Ω + PTC (10 Ω)
Non-powered unit .....	Rshunt = ∞, Vdrop < 6 V

#### Display:

Display readout .....	±9999 (4 digits)
Min. display readout (span) .....	0 counts
Decimal point .....	Programmable
Digit height:	
5515A (LED) .....	14.2 mm
5515B (LCD) .....	16 mm
Display updating .....	2.5 times/s
Backlight (LCD) .....	Light green
Input outside input range is indicated by:	
Nominal min. - 7% of span .....	In.LO
Nominal max. + 3.5% of span .....	In.HI
Sensor error is indicated in display by .....	SEnS
Readout > 9999 is indicated by .....	Flashing 9999

#### GOST R approval:

VNIIM, Cert No. .... Ross DK.ME48.V01899

#### Observed authority requirements: Standard:

EMC 2004/108/EC	
Emission and immunity .....	EN 61326
LVD 73/23/EEC .....	EN 61010-1
PELV/SELV .....	IEC 364-4-41
	EN 60742

**Of span** = Of the presently selected range

## OPTIONS INDEX FOR THE 5515 PROGRAMMABLE LCD/LED INDICATOR:

(Use this as a checklist when ordering configured units)

TYPE 5515-1 INPUT: RTD / TC / Lin. R / mV				TYPE 5515-2 INPUT: mA / Voltage	
<b>RTD type:</b> Pt100 (DIN/IEC) Ni100  Specify type : ___ Specify range °C : ___	<b>Thermocouple type:</b> Type B : Pt30%Rh-Pt6%Rh Type E : NiCr-CuNi Type J : Fe-CuNi Type K : NiCr-Ni Type L : Fe-CuNi Type N : NiCrSi-NiSi Type R : Pt13%Rh-Pt Type S : Pt10%Rh-Pt Type T : Cu-CuNi Type U : Cu-CuNi Type X : Special Type W3 : W3%Re/W25%Re Type W5 : W5%Re/W26%Re Specify type : ___ Specify range °C : ___	<b>Linear resistance range:</b> (30 Ω ≤ range ≤ 5000 Ω)  Specify range Ω : ___	<b>mV range:</b> 5 mV ≤ range ≤ +100 mV  Specify range mV : ___	<b>mA input range:</b> 4 mA ≤ range ≤ +100 mA  Specify range mA : ___	<b>Voltage range:</b> 50 mV ≤ range ≤ +250 VDC  Specify range VDC : ___
<b>RTD options:</b> 2-wire, no comp.: 3-wire compensation: 4-wire compensation: Specify wire : ___	<b>TC options:</b> Internal CJC External CJC, Pt100, Ni100 Constant CJC: (specify °C) Specify CJC : ___	<b>Resistance options:</b> 2-wire, no compensation: 3-wire compensation: 4-wire compensation: Specify wire : ___	<b>Linearisation:</b> No linearisation Customer linearisation (specify):		
<b>Response time:</b> 1 s ≤ response time ≤ 60 s Specify response time : ___					
<b>DISPLAY</b>					
Specify 0% display value : ___ Specify 100% display value : ___ Specify decimal point x,x,x,x : ___					

### Routing diagram:

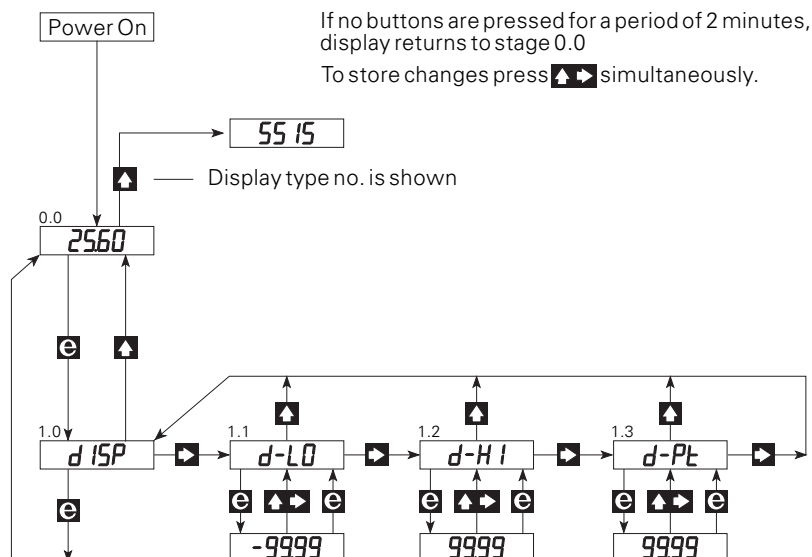

Order : 5515

Type	Display	Input	Supply
5515	LED : A	RTD / TC / mV / R : 1	115 VAC : A
	LCD : B	mV / V / mA : 2	230 VAC : B
			24 VDC / 24 VAC : D

**Note!** For TC inputs with internal CJC, remember to order the CJC connector type 5914.

Order: 5515A--PEAK

Special version of the 5515A. Select input and supply options from the order table.

**Block diagrams:**

Input: 1

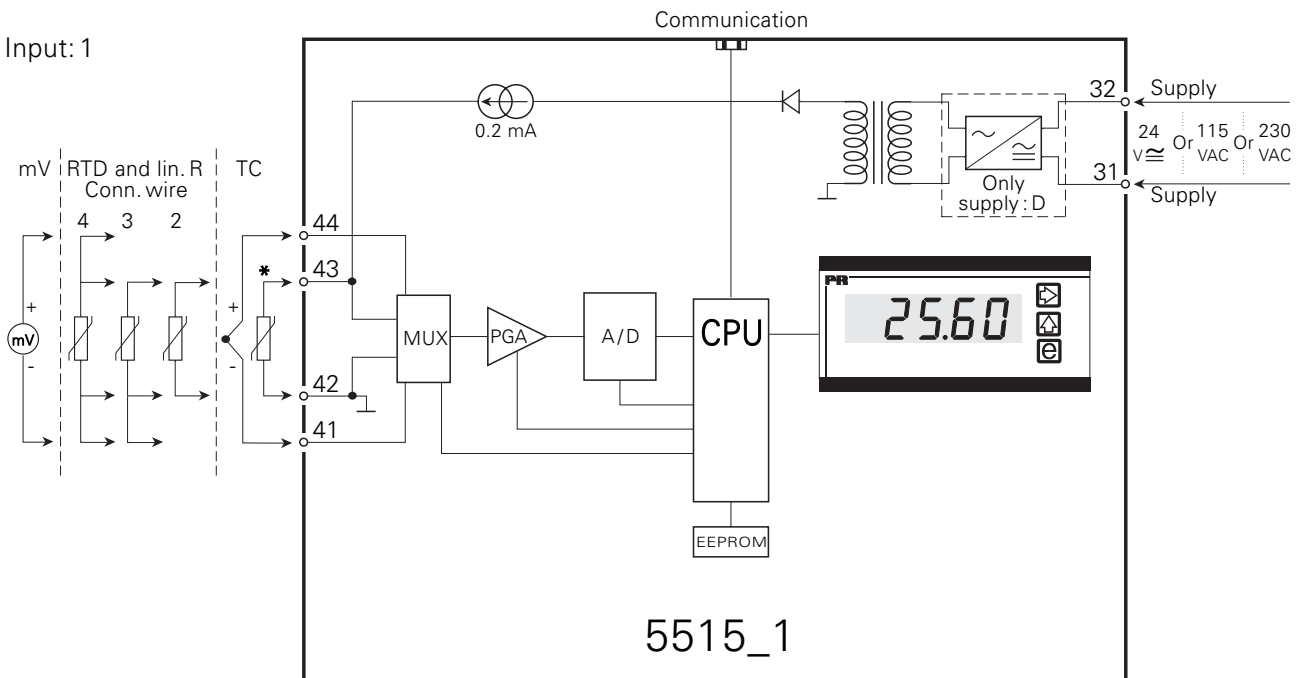

\* Accessories: 5914 CJC connector.

Input: 2

