

2-WIRE HART® TRANSMITTER



- **RTD, TC, Ohm, or mV input**
- **Extremely high measurement accuracy**
- **HART® communication**
- **Can be installed in Ex zone 0**
- **1- or 2-channel version**



Application:

- Linearised temperature measurement with Pt100...Pt1000, Ni100...Ni1000, or TC sensor.
- Difference or average temperature measurement of 2 resistance or TC sensors.
- Conversion of linear resistance variation to a standard analogue current signal, for instance from valves or Ohmic level sensors.
- Amplification of a bipolar mV signal to a standard 4...20 mA current signal.
- Connection of up to 15 channels to a digital 2-wire signal with HART® communication.

Technical characteristics:

- Within a few seconds the user can program PR6335B, C & D to measure temperatures within all ranges defined by the norms.
- The RTD and resistance inputs have cable compensation for 2-, 3- and 4-wire connection.
- The 6335B, C and D have been designed according to strict safety requirements and are thus suitable for application in SIL 2 installations.
- Continuous check of vital stored data for safety reasons.
- Sensor error detection according to the guidelines in NAMUR NE 89.

Mounting / installation:

- Mounted vertically or horizontally on a DIN rail. As the modules can be mounted without any distance between neighbouring units, up to 84 channels can be mounted per metre.
- **NB:** As Ex barrier we recommend 5106B.

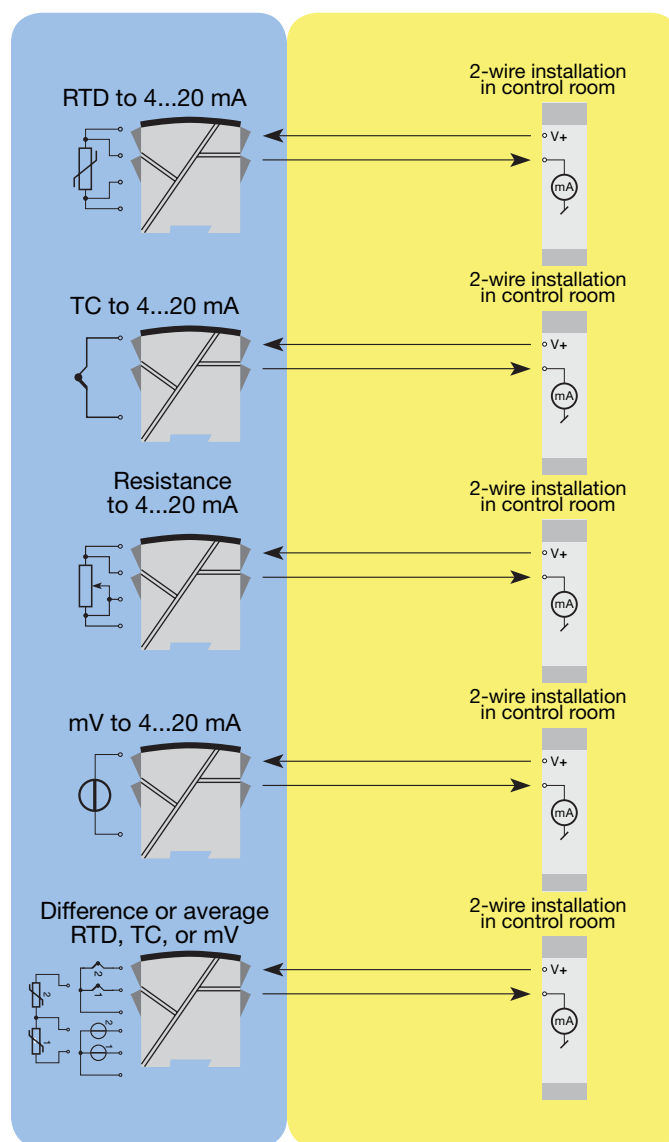

Order: 6335

Type	Version	Galvanic isolation	Channels
6335	ATEX : B	1500 VAC : 2	Single : A
	FM and ATEX : C		Double : B
	CSA, FM and ATEX : D		

*NB! Please remember to order CJC connectors type 5910EEx (channel 1) and 5913EEx (channel 2) for TC inputs with an internal CJC.

Connections:

All connection options are shown in the user manual.

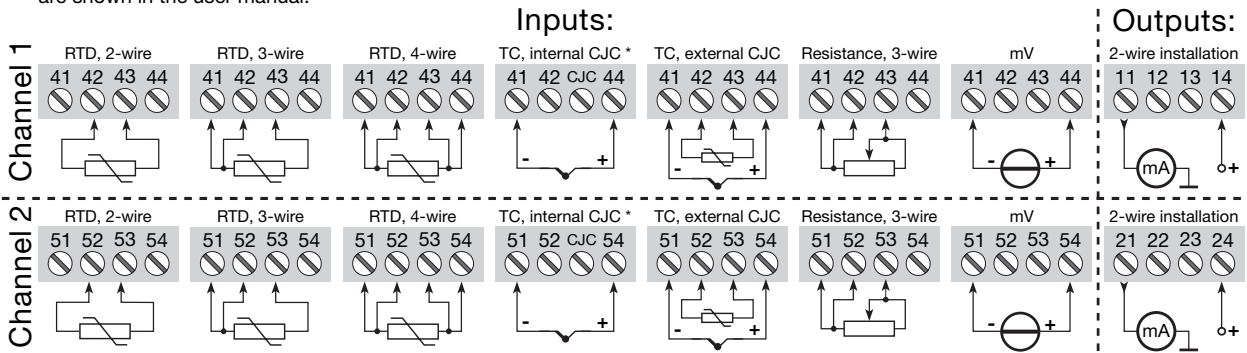

Electrical specifications:

Specifications range:

-40°C to +60°C

Common specifications:

- Supply voltage, DC 8.0...28 VDC
- Voltage drop 8.0 VDC
- Isolation voltage, test / operation 1.5 kVAC / 50 VAC
- Isolation voltage, ch. 1 / ch. 2 1500 VAC
- Communications interface Loop Link & HART®
- Signal / noise ratio Min. 60 dB
- Response time (programmable) 1...60 s
- Signal dynamics, input 22 bit
- Signal dynamics, output 16 bit
- Calibration temperature 20...28°C
- Accuracy, the greater of general and basic values:

TC input:

Type	Min. temperature	Max. temperature	Min. span	Standard
B	+400°C	+1820°C	100°C	IEC584
E	-100°C	+1000°C	50°C	IEC584
J	-100°C	+1200°C	50°C	IEC584
K	-180°C	+1372°C	50°C	IEC584
L	-100°C	+900°C	50°C	DIN 43710
N	-180°C	+1300°C	50°C	IEC584
R	-50°C	+1760°C	100°C	IEC584
S	-50°C	+1760°C	100°C	IEC584
T	-200°C	+400°C	50°C	IEC584
U	-200°C	+600°C	50°C	DIN 43710
W3	0°C	+2300°C	100°C	ASTM E988-90
W5	0°C	+2300°C	100°C	ASTM E988-90

General values		
Input type	Absolute accuracy	Temperature coefficient
All	≤ ±0.05% of span	≤ ±0.005% of span / °C

Basic values		
Input type	Basic accuracy	Temperature coefficient
Pt100 and Pt1000	≤ ±0.1°C	≤ ±0.005°C/°C
Ni100	≤ ±0.2°C	≤ ±0.005°C/°C
Lin. R	≤ ±0.1 Ω	≤ ±5 mΩ/°C
Volt	≤ ±10 μV	≤ ±0.5 μV/°C
TC type: E, J, K, L, N, T, U	≤ ±0.5°C	≤ ±0.025°C/°C
TC type: B, R, S, W3, W5	≤ ±1°C	≤ ±0.1°C/°C

EMC immunity influence	< ±0.1% of span
Extended EMC immunity: NAMUR NE 21, A criterion, burst	< ±1% of span

- Humidity < 95% RH (non-cond.)
- Dimensions (H x W x D) 109 x 23.5 x 104 mm
- Weight (1 / 2 channels) 145 / 185 g

Electrical specifications, input:

Max. offset 50% of selec. max. value

RTD and linear resistance input:

RTD type	Min. value	Max. value	Min. span	Standard
Pt100	-200°C	+850°C	10°C	IEC 60751
Ni100	-60°C	+250°C	10°C	DIN 43760
Lin. R	0 Ω	7000 Ω	25 Ω	-----

- Cable resistance per wire (max.) 5 Ω
- Sensor current Nom. 0.2 mA

Cold junction compensation < ±1.0°C

Voltage input:
 Measurement range -800...+800 mV
 Min. span 2.5 mV
 Input resistance 10 MΩ

Current output:

- Signal range 4...20 mA
- Min. signal range 16 mA
- Updating time 440 ms
- Load resistance ≤ (V_{supply} - 8) / 0.023 [Ω]

Sensor error detection:

Programmable 3.5...23 mA

Ex / I.S. data:

- U_i : 28 VDC
- I_j : 120 mADC
- P_i : 0.84 W
- L_i : 10 μH
- C_j : 1.0 nF

EEx / I.S. approval:

- DEMKO 99ATEX126961 II 1 G
EEx ia IIC T1...T6
- Max. amb. temperature for T1...T6 ... 60°C
- ATEX, applicable in zone 0, 1 or 2
- FM, applicable in IS, Cl. I, Div. 1, Gr. A, B, C, D
IS, Cl. I, Zone 0, AEx ia IIC
- Entity, FM Installation Drawing No. ... 6335QF01
- CSA, applicable in IS, Cl. I, Div. 1, Gr. A, B, C, D
Ex ia IIC
IS, Cl. I, Zone 0, AEx ia IIC
- Installation Drawing No. 6335QC02

GOST R approval:

VNIIFTRI No.RossDK.GB06.V00100

Observed authority requirements: Standard:

- EMC 2004/108/EC
Emission and immunity EN 61326
- ATEX 94/9/EC EN 50014 and EN 50020
- FM, ASCN 3600, 3611, 3610
- CSA, CAN / CSA C22.2 No. 157,
E60079-11, UL 913

Of span = Of the presently selected range